



TECHLINK

Associated International Engineers

NON-METALLIC CONTROL VALVES FOR CORROSIVE CHEMICALS



N-Series

BELLOWS SEALED

FLOW CONTROL PRINCIPLE

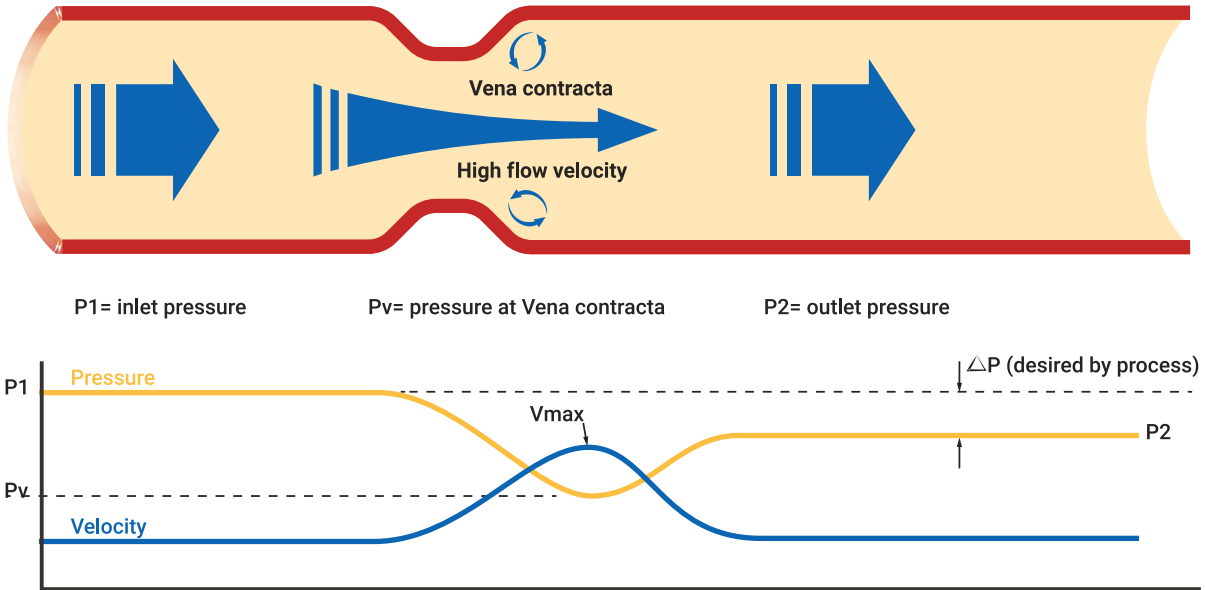

In a control valve, the flow is forced through the control valve orifice by the pressure difference across the valve. The actual flow area is smallest at the point called the vena contracta.

Due to the reduction in flow area, a significant increase in flow velocity has to occur to give equal amounts of flow through the valve inlet area and vena contracta area. The energy for this velocity change is taken from the valve inlet pressure, which gives a typical pressure profile inside the valve.

The pressure inside the valve drops as the effective flow area is reduced, up to the vena contracta point. After reaching the vena contracta point the velocity of the flow is reduced due to the fact that more flow area becomes available to the flow. Thus some of the pressure lost up to the vena contracta point is recovered.

The pressure recovery after the vena contracta point depends on the valve style and type.

The pressure difference (ΔP) between inlet (P1) and outlet (P2) of the valve is what allows the control of liquid flow.

Key points :

- Residual head loss is what we need to control the flow or the pressure
- **Different types of control valves need different pressure drop for the same resulting ΔP**
- High pressure drop means high velocity rise
- High flow velocity is damaging to the trim materials
- **Low velocity means longer life**
- Low-pressure recovery designs improve lifetime

Accuracy and precision:

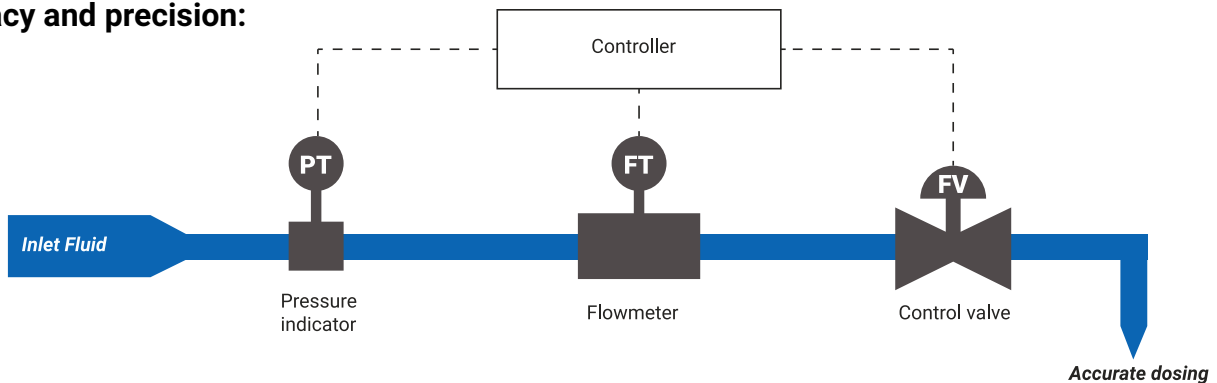

Precision and accuracy of flow control can only be achieved with a control loop. This control loop is programmed integrating inputs and outputs of the flow control equipment.

VALVE MATERIAL

Where the flow velocity is high, corrosive chemicals cause unexpected kinds of damage to the materials. In the vena contracta, metals will show signs of erosion-induced corrosion, even if they are corrosion-resistant as piping or body materials. PFA or PTFE lining will erode quickly, particularly when the valve is used with a high delta-P. Once eroded, the base metal, usually cast iron, is quickly attacked, causing a severe leakage to the outside. TECHLINK non-metallic flow control valves are the longest lasting solution for controlling the flow of corrosive water based chemicals because no metals are used in the construction of the flow related components.

WHY NON-METALLIC MATERIALS?

The corrosion resistance of metals is generally appreciated in still fluids (static situation). But at high flow speeds and in the presence of turbulence, a process known as « erosion induced corrosion » starts destroying even the so-called « corrosion resistant » metals.

In such situation, solid polymers may offer an economic solution, that will outperform even “special metals” and other exotic materials.

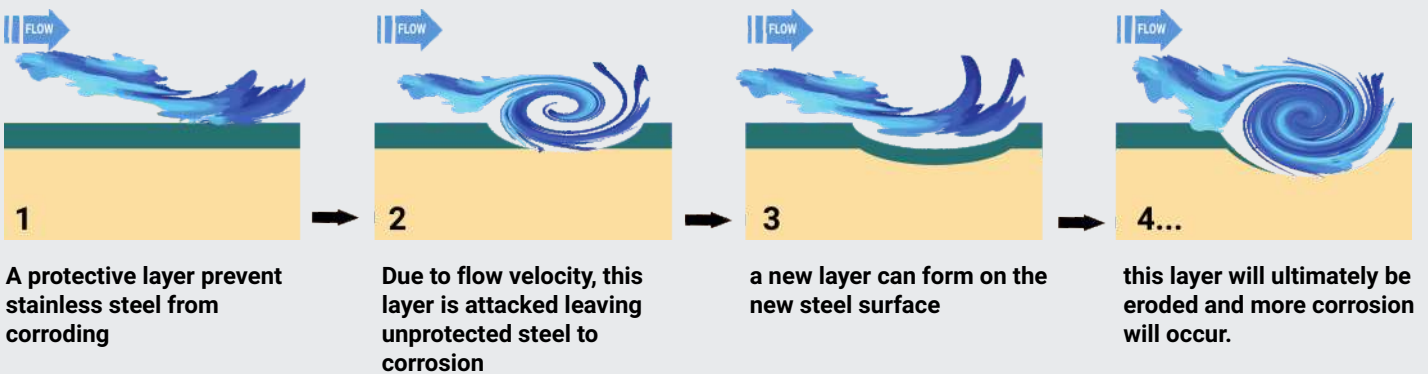

BEST CHOICE IN POLYMER MATERIALS

Polymers are not equal when it comes to resisting high flow velocities, turbulence and erosion, as well as chemical attack. The table below shows the abrasion resistance of several polymers, as determined by the “TABER” ASTM D4060 test. The lower the figure, the better is the resistance.

Apart from polyamid, which cannot be used because of its low chemical resistance, the best abrasion resistant material is PVDF. This material should be preferred for all parts of the valve making up the “Vena contracta”

Key points :

- PVDF is best : Chemical resistance & Erosion resistance**
- PPH or ECTFE is the best alternative where possible**

Material	Weight loss (mg/1000 rev.) ASTM D4060, wheel CS-10
PVDF homopolymer (SOLEF®)	5 - 10 ✓
PVDF, SOLEF® 21508/31508	5 - 8 ✓
PA 6 polyamid	5
ECTFE, Halar®	13 ✓
PP homopolymer	15 - 20 ✓
PTFE	500 - 1000 ⚠
304 stainless steel	50

When PVDF cannot be used for chemical reason, such as in concentrated hydroxides, then PPH and ECTFE are acceptable alternatives. It is readily seen that PTFE, which has the lowest abrasion resistance of all polymers, is the worst choice for contact with the flow in the Vena Contracta.

VALVE DESIGN

The range of TECHLINK compact control valves type N covers flows of 5 liters/h to 10 m³/h under 1 bar ΔP, with either a linear response, or an Equal Percentage response.

GLOBE TYPE :

TECHLINK compact control valves type N are globe valve design. This valve type is well regarded as the best design for control valves. this design has low acceleration in the flow restriction area, good sealing capability and great throttling.

The extensive experience of TECHLINK in control valves integrate a polymer bellow seal for the best leakage prevention in a fully non-metallic valve.

Our improvement on plug disks; the needle design ensure excellent flow control and specific response curves.

SAFE LEAKAGE-FREE SEALS :

Corrosive chemicals are often also toxic, or dangerous chemicals. Control valve type N have sophisticated seals to guarantee a safe and leakage free service, compliant with ISO 15848-1 Class A-RT.

NEEDLE SHAPE :

For controlling small flow rates, solid polymer needle valves are best. CV values as low as 0.01 can b accurately controlled with optimum stability. Seat diameters of 4 mm up to 18 mm allows a wide range of flow to work with.

The needles profiles are carefully studied and designed to provide the desired flow characteristic curves.

STEM SEALING :

SECONDARY STEM SEAL :
Six rings PTFE chevron gland packing

PRIMARY STEM SEAL :
Long PTFE bellows

DISC SEALING :

SHARP EDGE BODY SEAT
PTFE free, for a combination of erosion resistance, and perfect disc/seat sealing, with a bubble free Class VI performance as per IEC 60534-4

PRECISELY CONTOURED DISC
Providing a carefully designed Equal Percentage response.

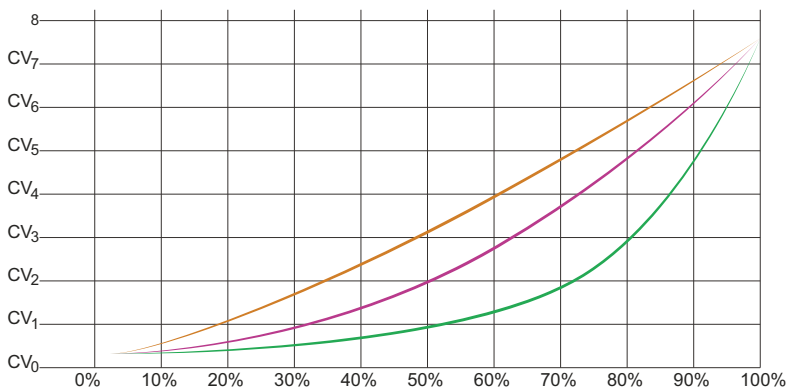
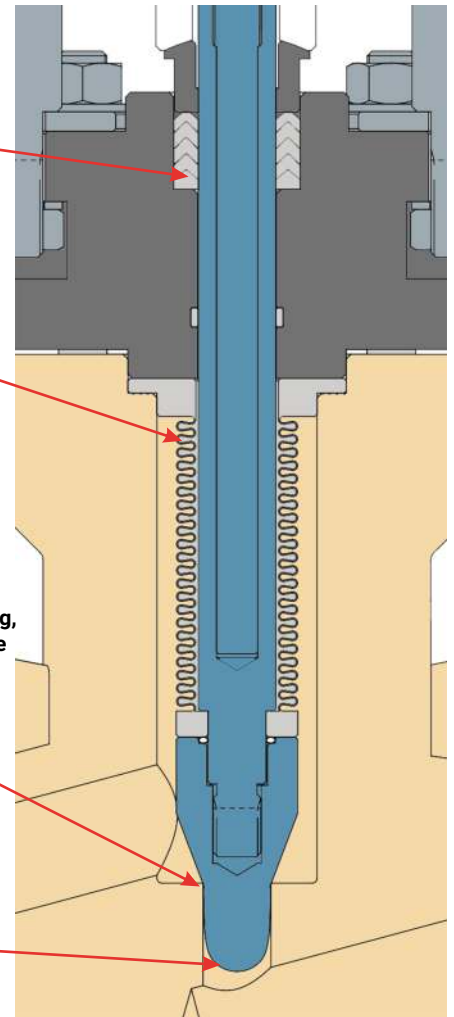

— Quasi-linear
— Soft EQ%
— Deep EQ%



A DESIGN DEDICATED TO CORROSION RESISTANCE

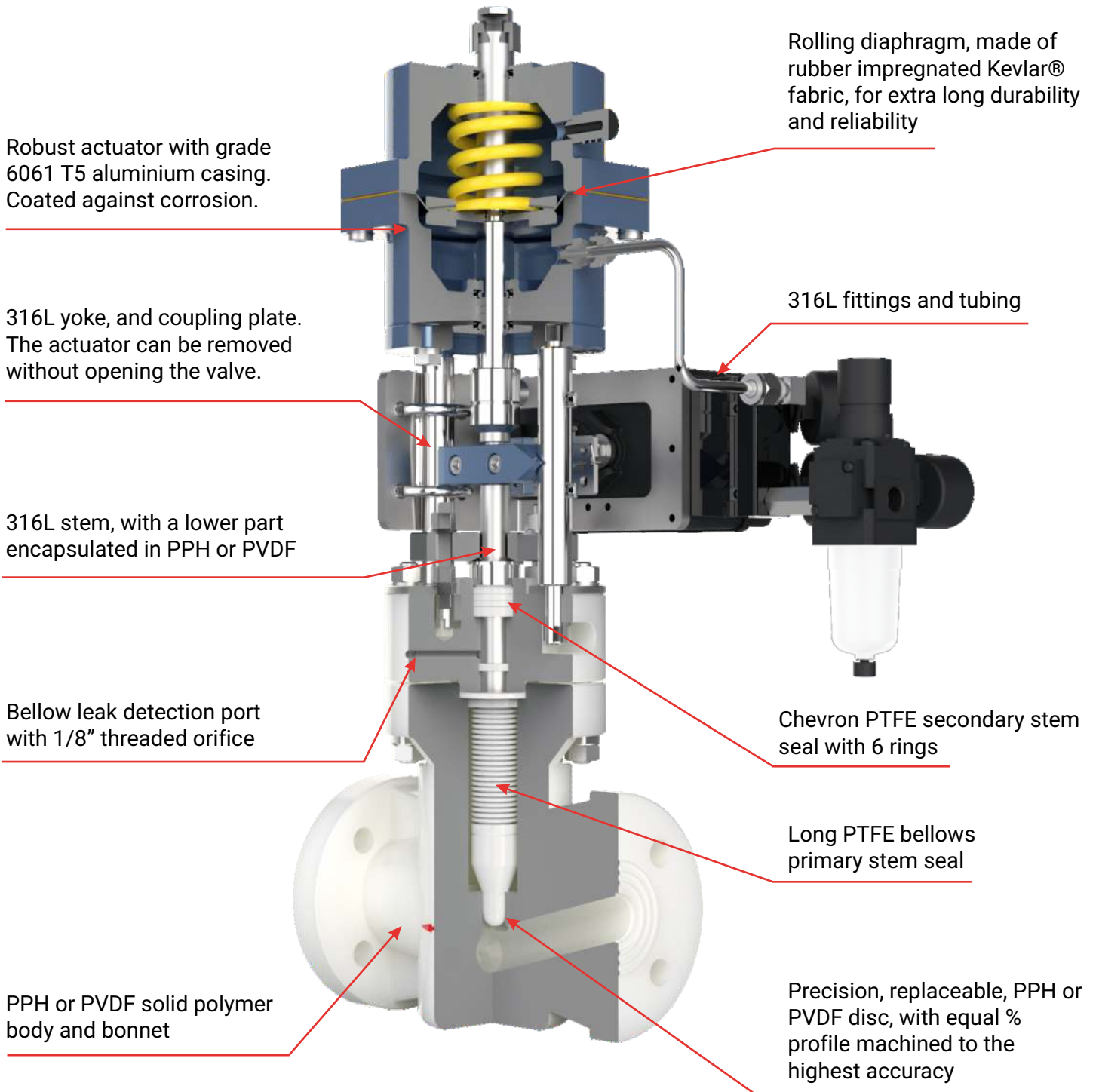

Flanges available to EN 1092-1-PN10, or to ASME B16.5 class 150

TECHNICAL DATA

PRESSURE RANGE	VACUUM TO 1 Mpa G
TEMPERATURE RANGE	-5°C to 80°C (PPH) 100°C (PVDF)
CONNECTION STYLE	FLANGED
CONNECTION SIZES	DN 15, DN 20, DN 25
FLANGES STANDARDS	EN 1092-1 PN10 , or ASME B16.5 150#
FACE-TO-FACE LENGTH	EN 558-1
BODY MATERIALS	PPH, or PVDF
DISC MATERIALS	PPH, or PVDF
BELLOWS MATERIAL	PTFE
O-RINGS MATERIALS	EPDM or FKM or FFKM
YOKE, BOLTING AND FITTINGS	316 L
STEM PRIMARY SEAL	BELLOWS
STEM SECONDARY SEAL	CHEVRONS GLAND PACKING
ACTUATOR TYPE	DIAPHRAGM
ACTUATOR CYLINDER MATERIAL	ALUMINIUM 6061 T5
DIAPHRAGM MATERIAL	NITRILE RUBBER COATED KEVLAR
MIN. AIR PRESSURE REQUIRED	0.45 Mpa
FAIL ACTION	OPEN, CLOSE, or DOUBLE ACTION
POSITIONER TYPE	FLAP & NOZZLE
POSITIONER (RECOMMENDED)	SAMSON 3725 or 3730
TRIM TYPE	EQUAL % or LINEAR
TIGHTNESS CLASS	CLASS VI (IEC 60534-4)

PRESSURE/TEMPERATURE RESISTANCE CURVES

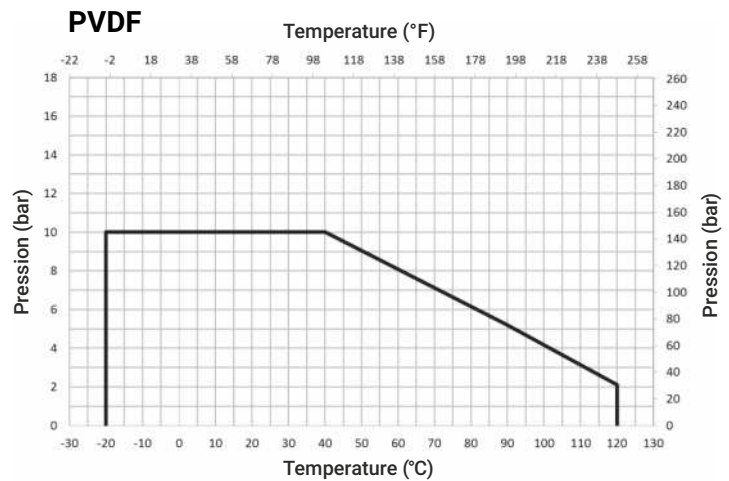
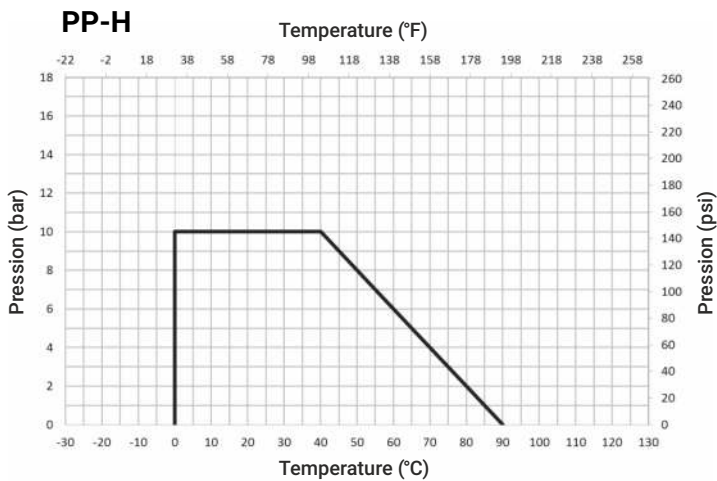

MATERIALS LIST

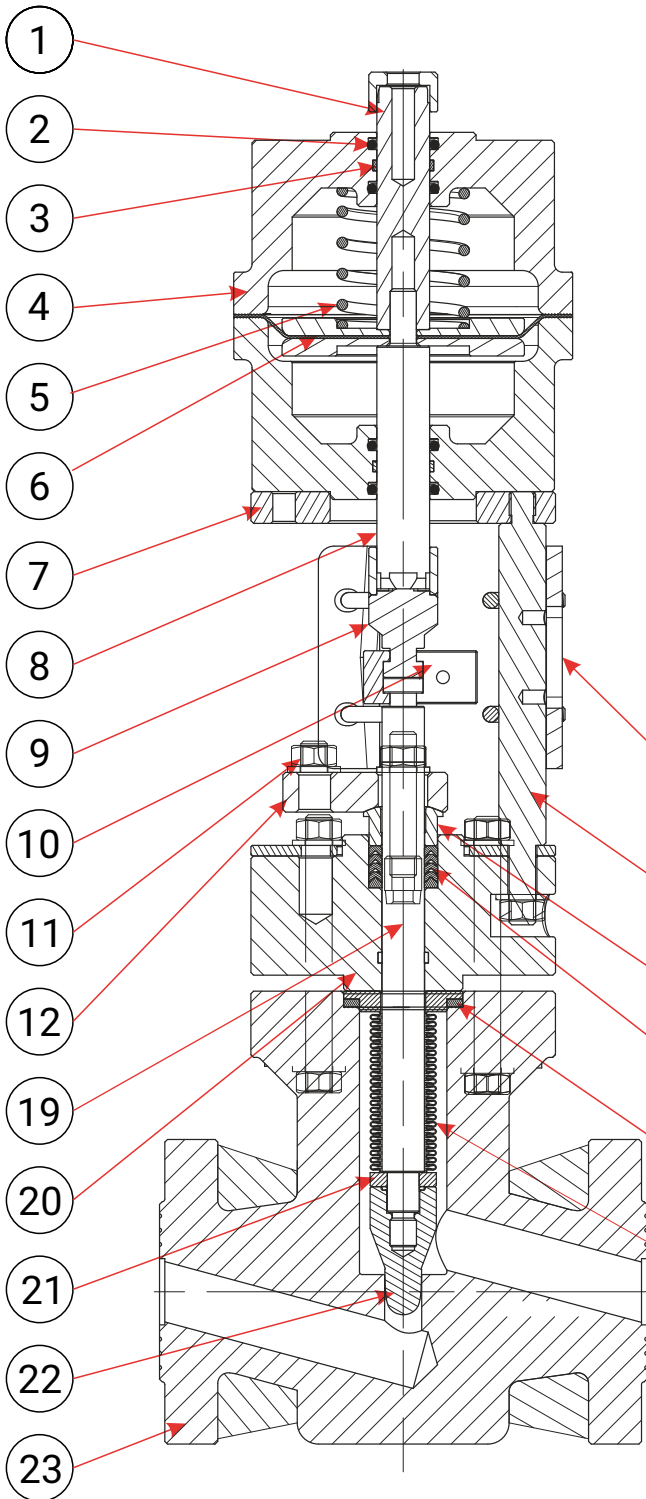

Item #	Description	Material
1	Actuator upper stem	316L
2	Stem seal	EPDM
3	Stem bearing	Graphite PTFE
4	Actuator body	Al 6061 T5
5	Spring	SWOSØ + epoxy
6	Diaphragm	Kevlar + NBR
7	Junction plate	316L
8	Actuator lower stem	316L
9	Stem coupling piece	316L
10	Stem index bar	316L
11	Gland bridge bolt	316L
12	Gland bridge	316L
13	Positioner adapter	316L
14	Yoke pillar	316L
15	Gland compressor	316L
16	Gland packing	PTFE
17	Body/Bonnet gasket	PTFE
18	Bellows	PTFE
19	Stem	PPH + 316L core
20	Bonnet	PPH or PVDF
21	Disc seal	EPDM or FKM
22	Disc	PPH or PVDF
23	Body	PPH or PVDF

- 13
- 14
- 15
- 16
- 17
- 18

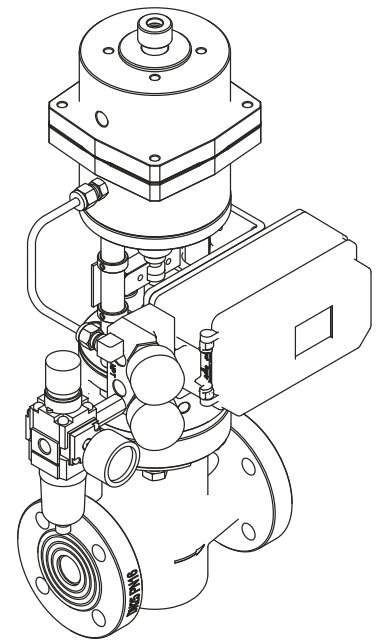

OVERALL DIMENSIONS

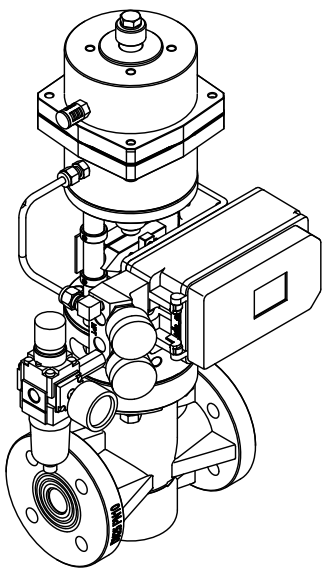
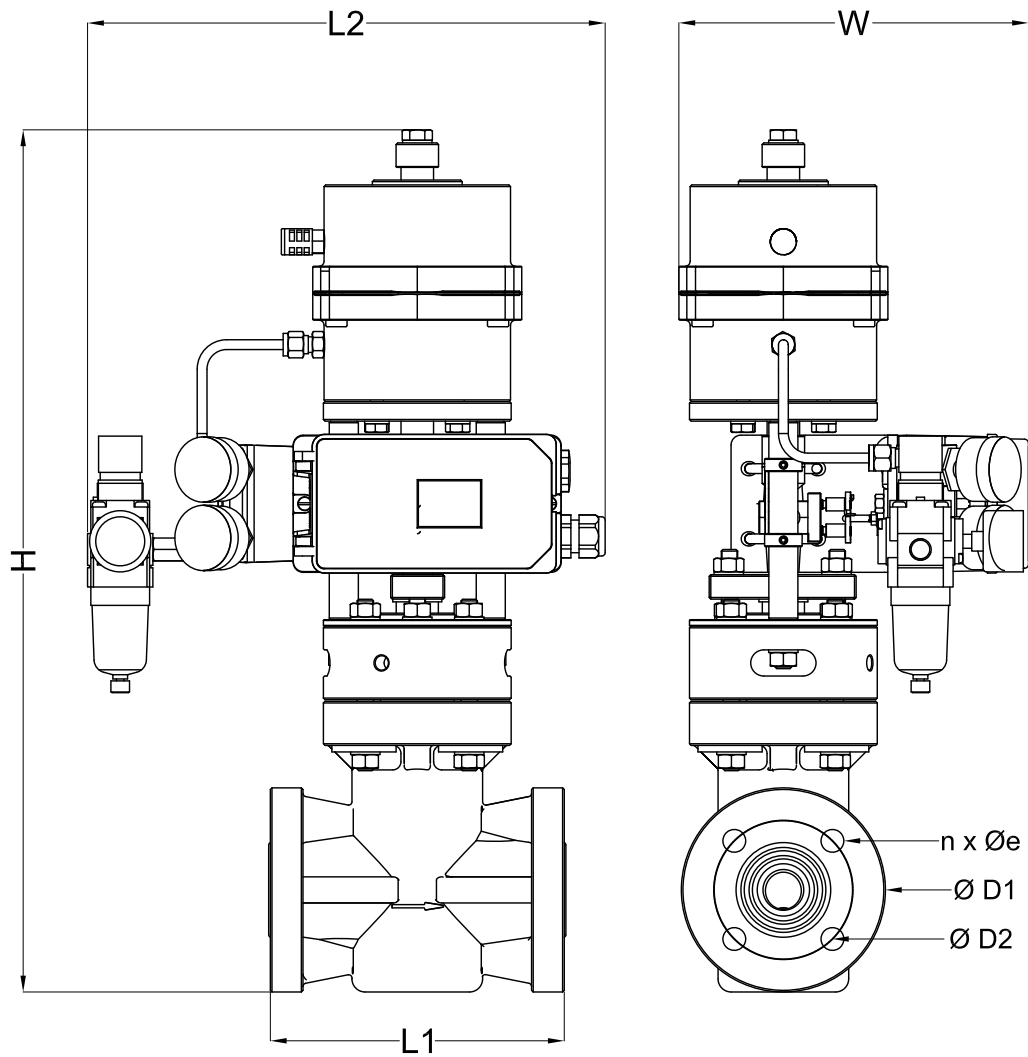

ANSI	ØD1 mm	ØD2 mm	Øe mm	n	H mm	L1 mm	L2 mm	W mm
1/2"	95	60.3	16	4	518	130	317	214
3/4"	105	70	16	4	523	150	317	214
1"	125	79.4	16	4	528	160	317	214

DIN	ØD1 mm	ØD2 mm	Øe mm	n	H mm	L1 mm	L2 mm	W mm
15	95	65	14	4	518	130	317	214
20	105	75	14	4	523	150	317	214
25	125	85	14	4	528	160	317	214

Installed with Samson 3730

ASSEMBLY EXPERTISE

A TECHLINK non-metallic N-Type control valve can be delivered with either a LINEAR characteristic or an EQUAL PERCENTAGE characteristic. All our models are tested on our test loop. Individual valves may, at the customer's request, be loop-tested, and the test report delivered with the valve.

Our engineers will calculate the most suitable combination of orifice size and needle contour from the customer's process data.

They will also advise on the best equipment suitable to the process:

To avoid undesirable stress and deformation of the valve structure, the associated accessories should be as light as possible. Whenever they exist, and except when they are prohibited by explosion zone rules, equipment with non-metallic bodies or casing are preferred. Heavy top-work needs to be supported and is not recommended.



POSITIONERS

TECHLINK control valves are normally fitted with SAMSON positioners type 3725 or 3730. Different options are available.

Model 3725 is recommended for its favorable cost and its corrosion-proof plastic casing.

Models of the 3730 series are recommended for their options, and highest precision.

Positioners of other brands are available on request, subject to prior testing and validation.

Positioner auto-tune, and valve functional testing is always performed on our valves, which are supplied "ready to use".



TECHLINK FLOW CONTROL GLOBE VALVES PRODUCT CODES

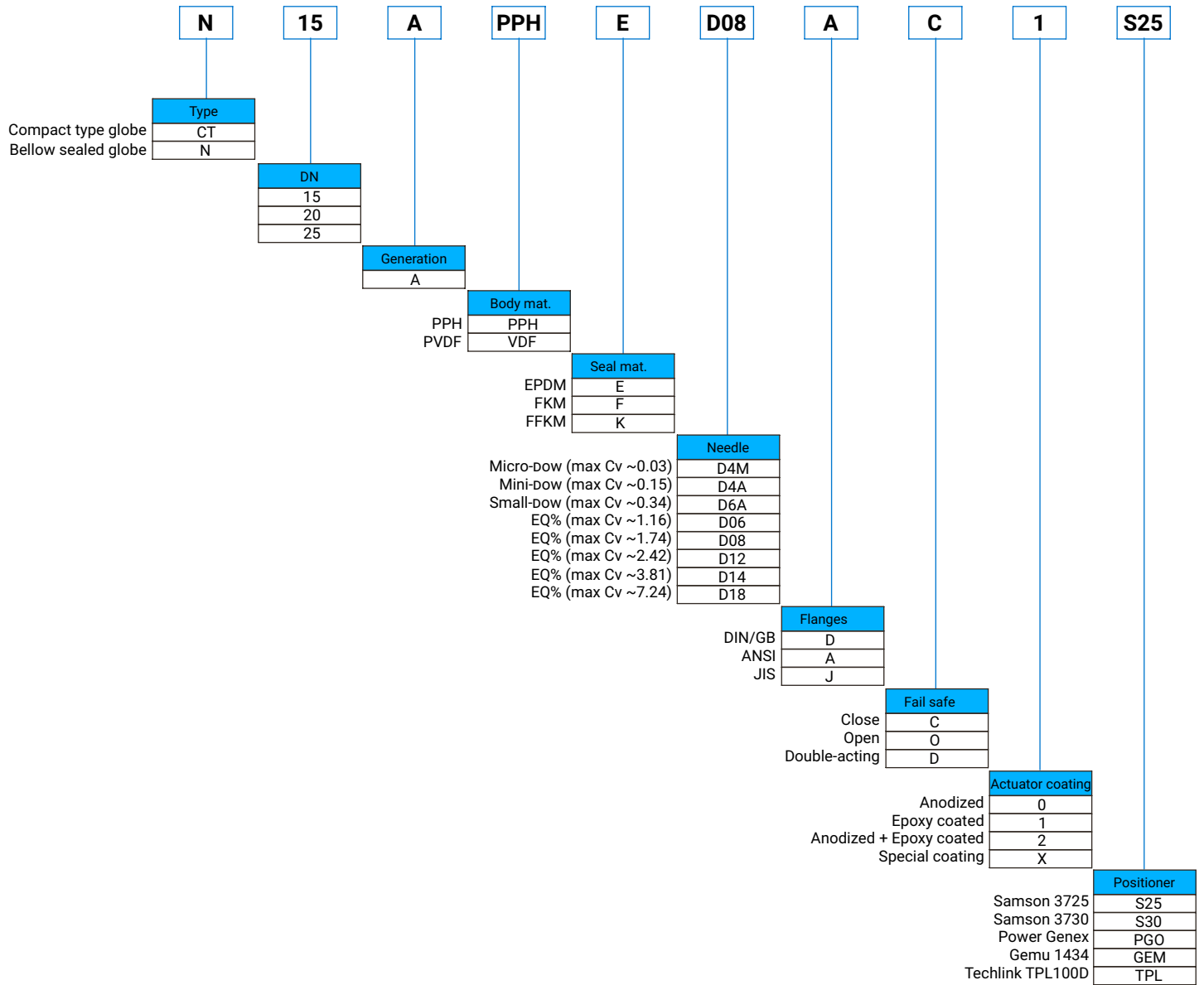



**State of the art innovation in flow control of
corrosive chemicals.**



FRANCE (HEADQUARTER)

TECHLINK Sarl

4c rue de la Ladrie
59290 Wasquehal
FRANCE

Tel : +33 320 05 00 45

www.techlink.fr

CHINA

TECHLINK SHANGHAI LTD.

Room 306 & 307, n758 Songsheng road,
Songjiang District,
Shanghai 201614, P.R. CHINA

Tel : + 86 21 57783957, 57783967

FAX : + 86 21 57784017

www.tech-link.asia

THAILAND

TECHLINK BANGKOK

Thai Virawat building
16TH floor, 16F
86/1 Krungthonburi Road,
Klongsan 10600,
THAILAND

Tel : +66896606955

www.tech-link.asia

INDIA

TECHLINK International Process Engineers Pvt. Ltd.

111 - Bholesal Complex, 3rd floor,
Main road, Cha Rasta, Fatehpura,
Vadodara - 390006
Gujarat, INDIA

Tel : +91 265-2324255

Mob: +91 8128057025

www.tech-link.com